

M A T R I X
800
U S E R M A N U A L

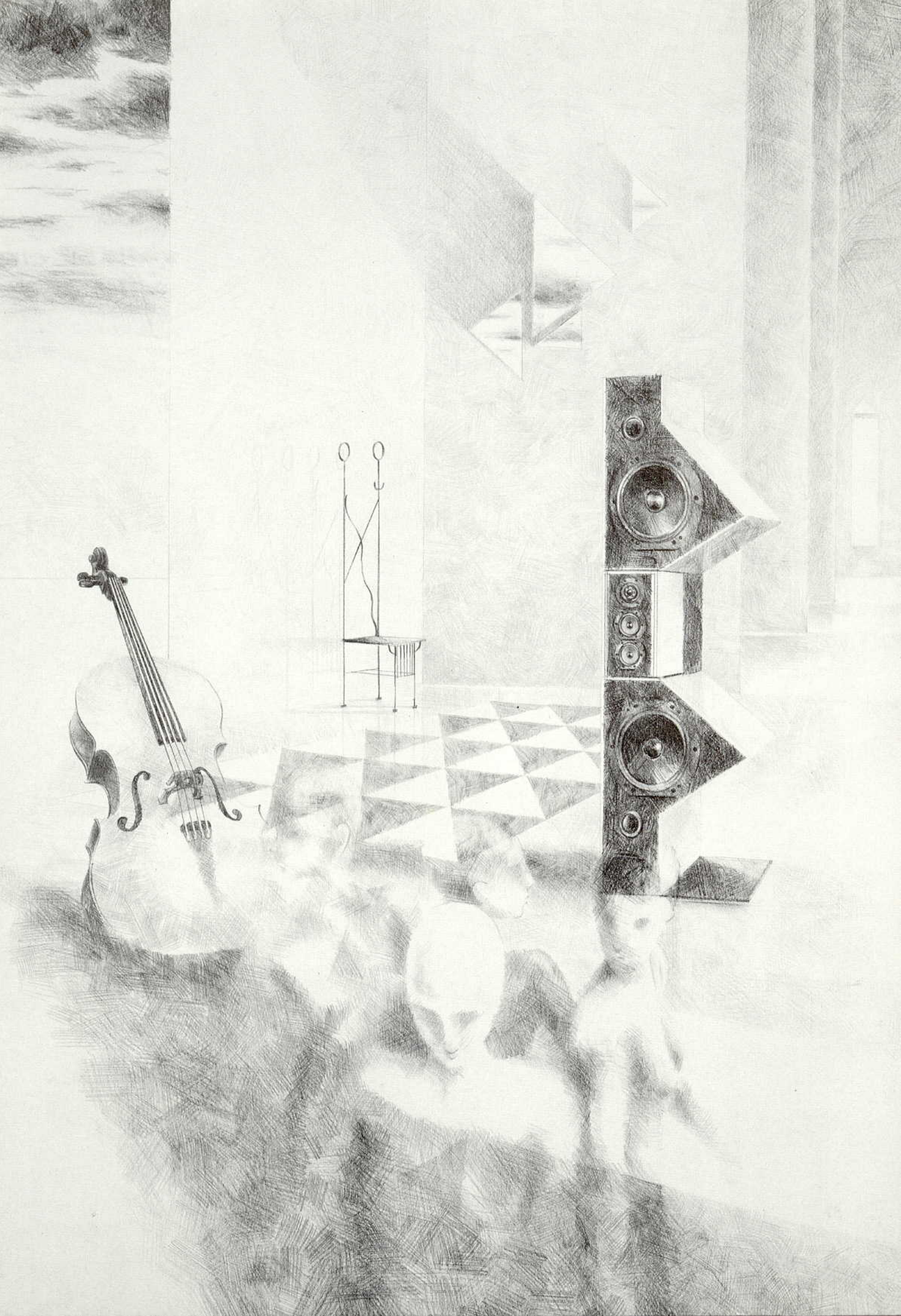



B&W
LOUDSPEAKERS

M A T R I X
800

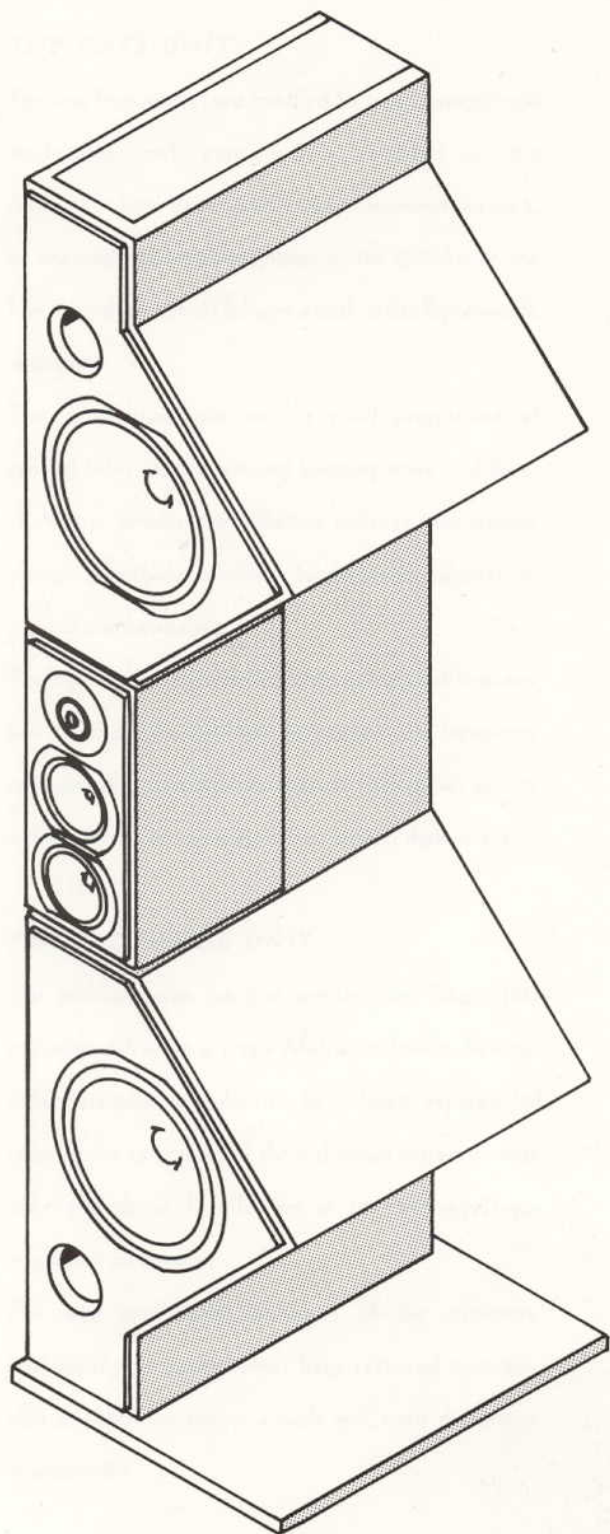

**INTRODUCING THE
B&W MATRIX 800**

Your Matrix 800 loudspeaker system is an extension of the now legendary Matrix 801, and incorporates many of the features which have contributed towards the enviable reputation which the latter enjoys as the classical recording industry's chosen monitor. The 800 could be described as the ultimate digital monitor in that its dynamic capabilities are awesome.

Peak power handling of around 800W and a free-field sensitivity of 93dB/2.83V/1m translate to around 120dB at 4m (15.6in) in a normal listening environment.

It goes without saying that Matrix 801's accepted virtues of neutrality and low coloration have been repeated in Matrix 800.

The aim of this manual is to ensure that you understand the principles behind your system and derive the maximum pleasure from it.

The design background follows, and later sections dealing with ancillary equipment, and the effects of the immediate environment, provide further useful advice.

A carefully vetted distribution network handles B&W products in more than 50 countries worldwide. Should a problem arise that your local dealer cannot resolve, the area distributor will be more than willing to help.

Thank you for the confidence and perception you have demonstrated by purchasing B&W Matrix 800 loudspeakers. Please read this manual carefully. It is an assurance of our continuing interest in your long-term listening pleasure.

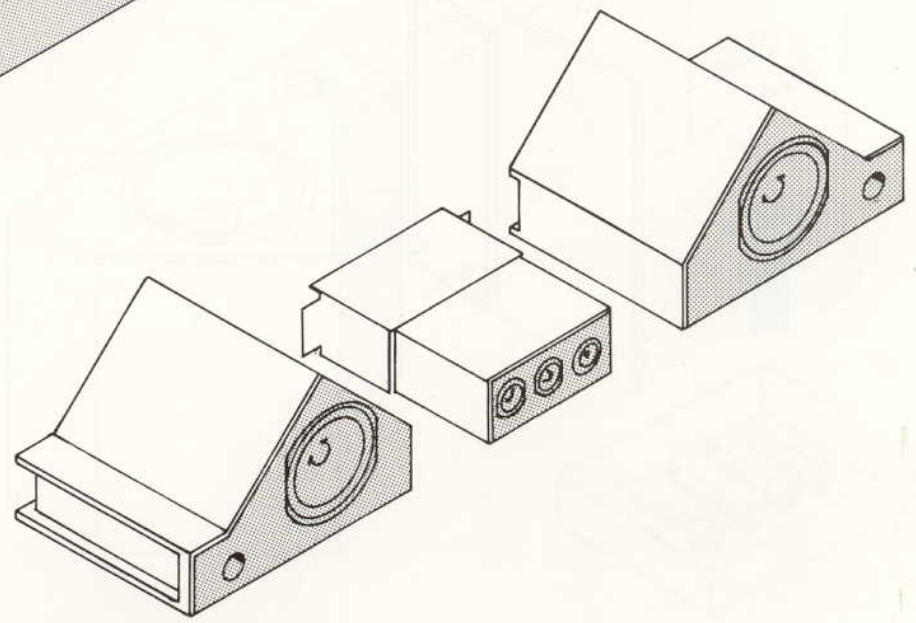
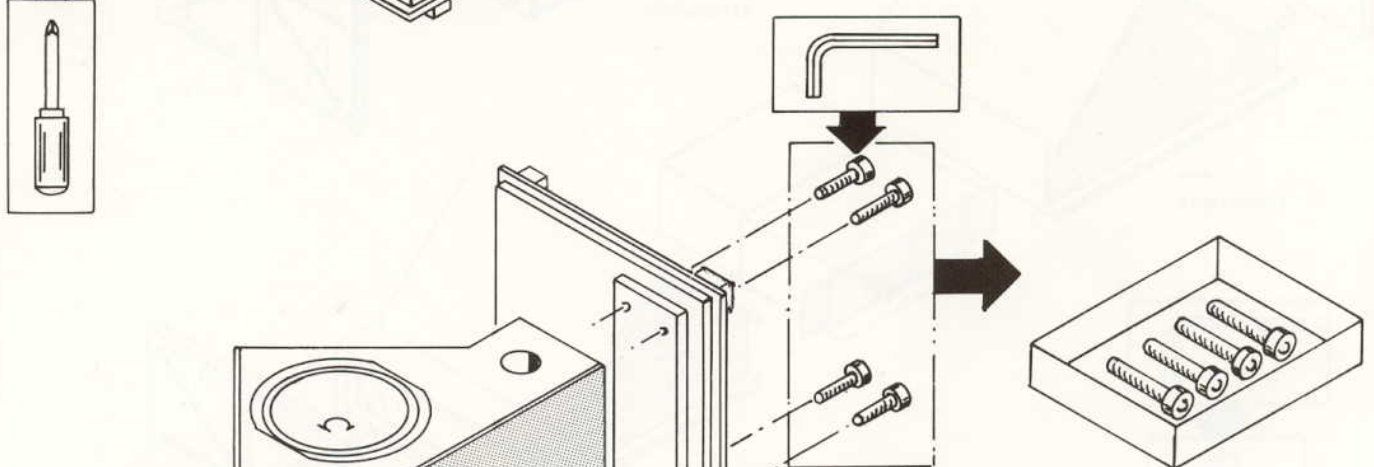
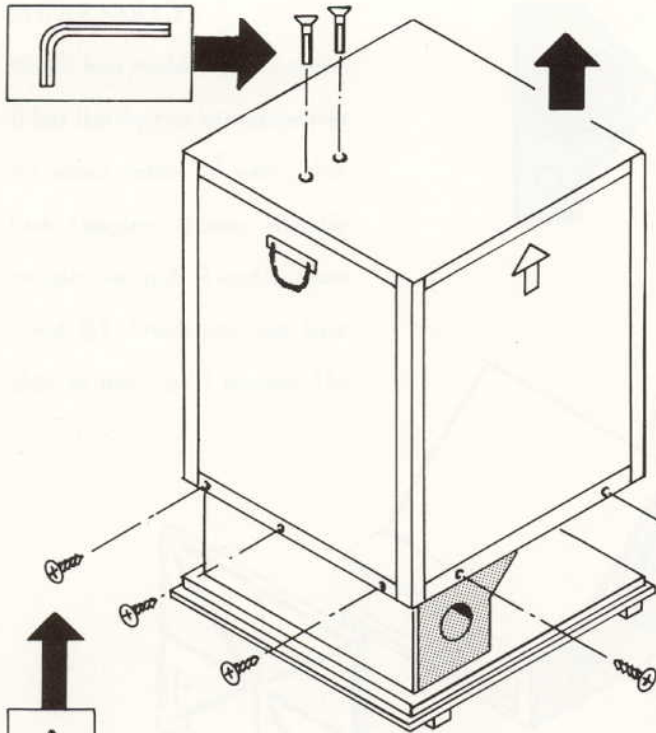

BASS MODULES

Each bass module has four fixing bolt positions on its base and two on the lid.

These are utilised in the assembly of the module in the packing, and can be readily seen on the top and underside of each of the four larger cases.

To unpack each bass module, stand it upright (handles at the top) and, using the medium size Allen key, remove the two socket head bolts from the lid. Remove all wood screws which attach the base only to the outer packing sleeve, and remove the sleeve.

Remove the internal card sleeve, then lay the assembly onto its back with the grille facing upwards and remove the four remaining Allen bolts.

Retain these four bolts for later use in assembly of the systems.

All other packing material and transit bolts should be retained for future transport of the systems. For your convenience, the sleeves used in the packing are designed with flexible metal corners, which allow them to be folded flat for easier storage.

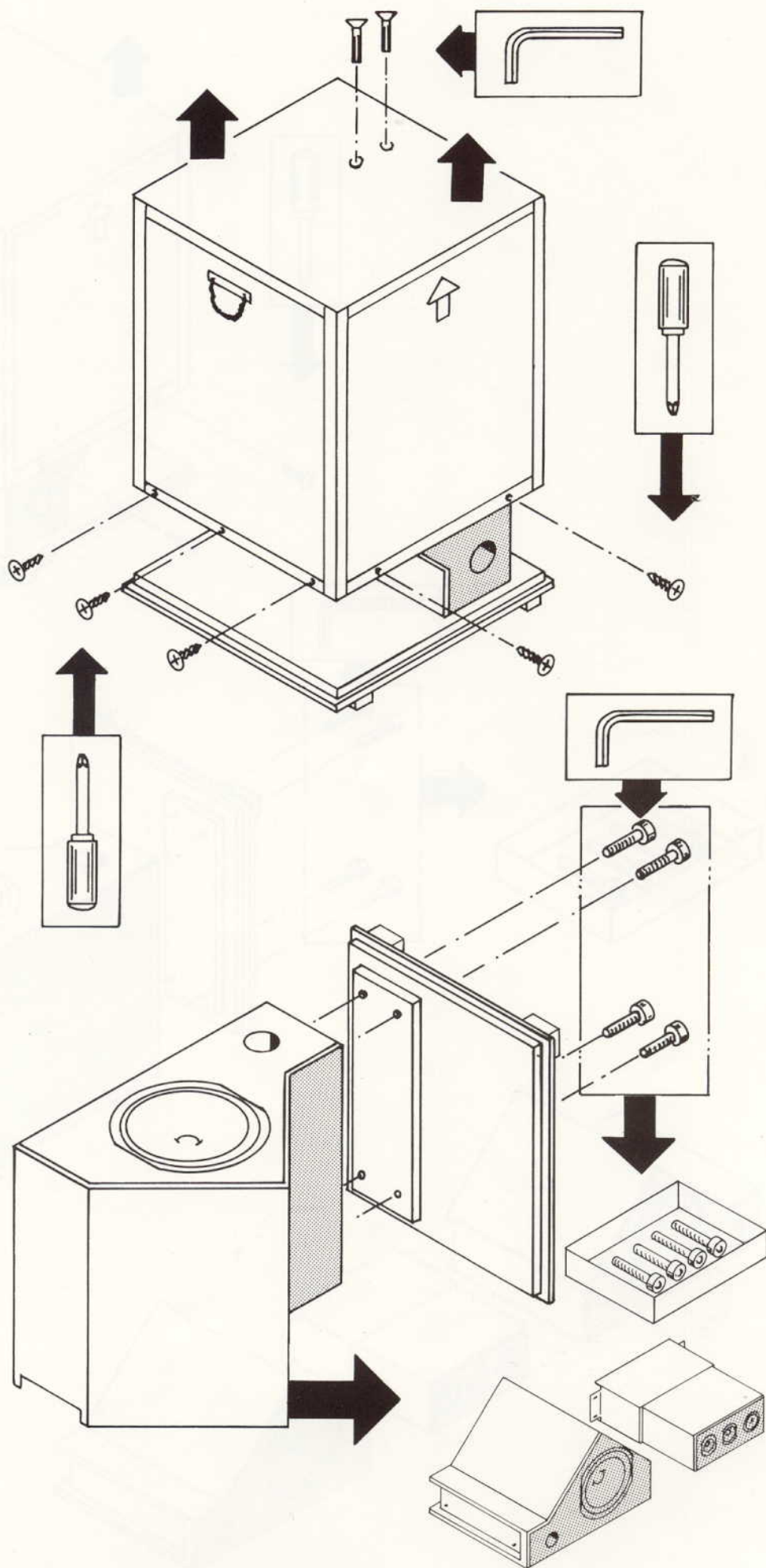

UNPACKING

Unpacking is straight-forward provided the following procedures are followed.

MIDRANGE/ HIGH-FREQUENCY MODULES

The two smaller cases contain the midrange/high-frequency modules which are fully assembled to the main steel bridge sections.

Stand the case upright (handles at the top). Remove all wood screws attaching the lid to the outer packing sleeve.

Remove the lid to reveal the mid-range enclosure and the cast base, attached to a wooden sub-plate.

Remove the two screws which secure the sub-plate to the sleeve, and slide the assembly out of the sleeve. Remove the four bolts to release the cast base from the sub-plate.

Remove the remaining wood screws from the base of the sleeve, and then the sleeve. The top cover plate is attached to the inside of the sleeve by two wood screws.

Finally remove the bolts securing the midrange/high-frequency assembly to the base of the packing.

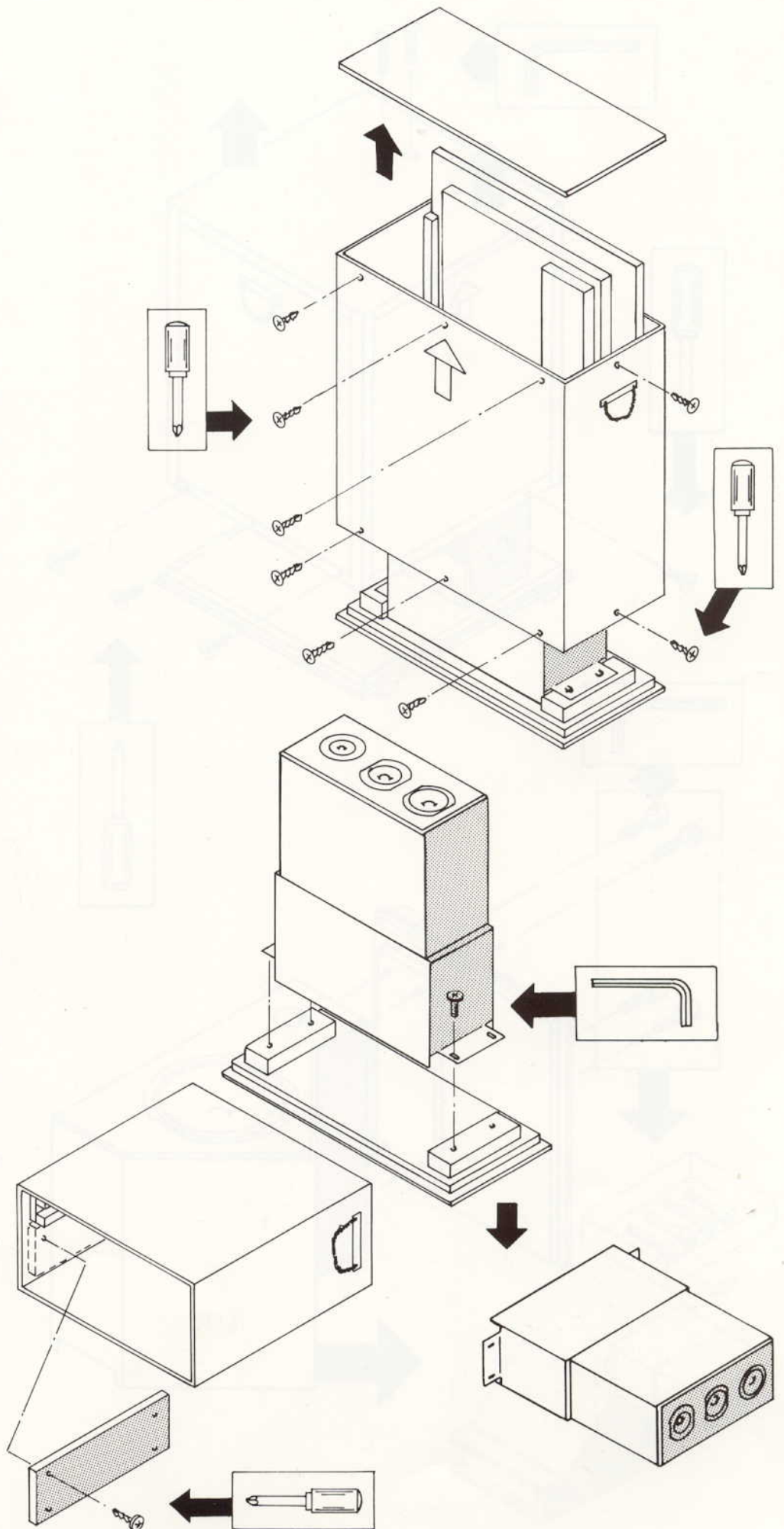

UNPACKING

Each pair of Matrix 800 systems is supplied in six separate cases containing:

Two type 1 bass modules.

Two type 2 bass modules.

Two midrange/high-frequency modules, each with one cast base plate and one top cover plate.

And in one midrange/high frequency case only, one accessory pack containing eight adjustable stainless steel floor cones, sixteen M8 × 25mm (1in) socket head bolts, and three Allen keys.

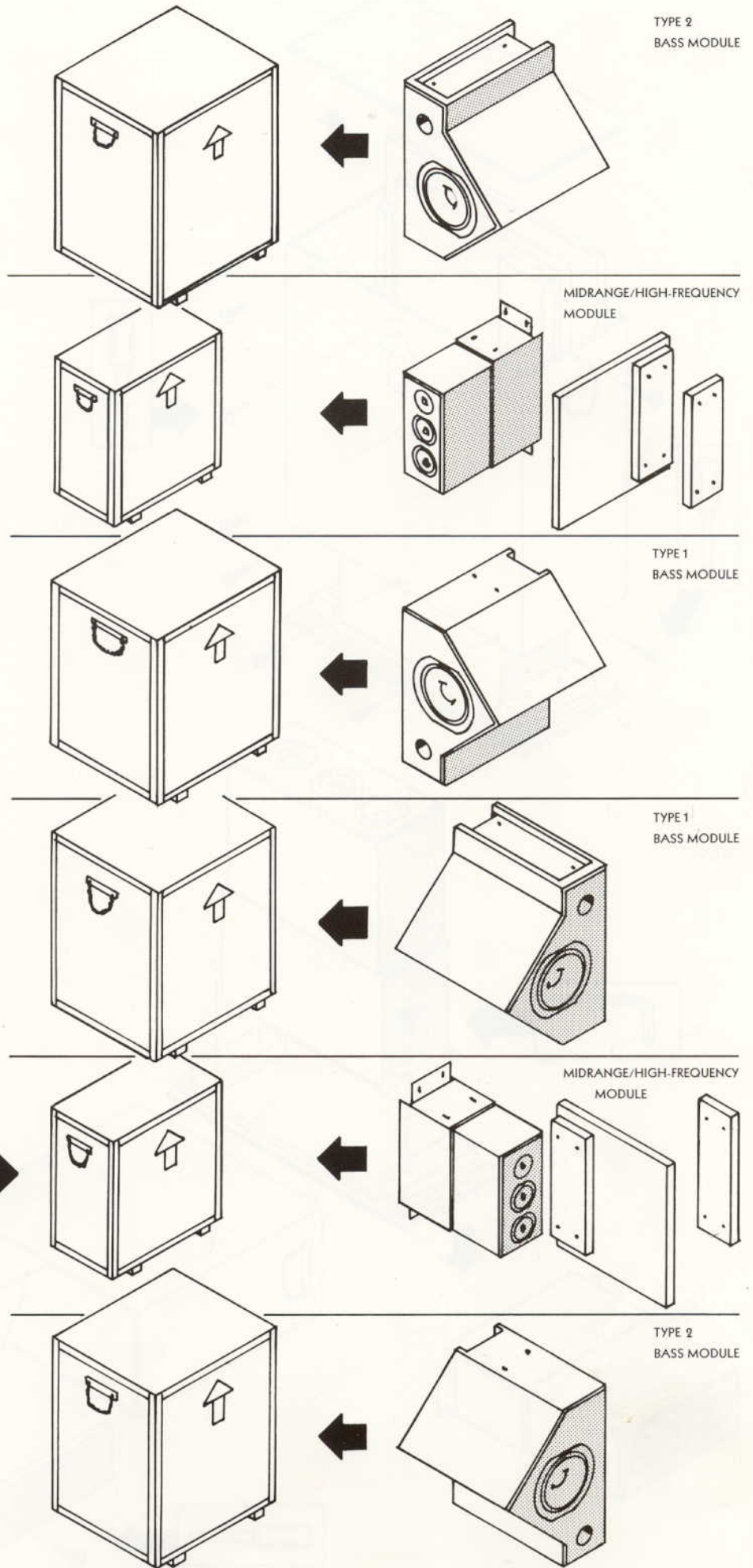
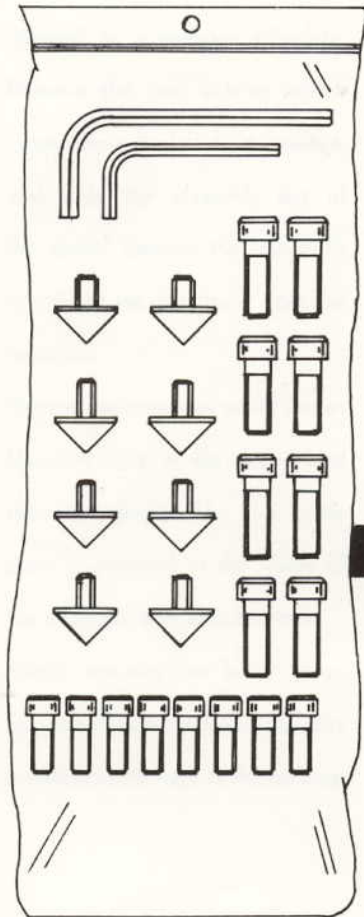

TYPE 2
BASS MODULE

MIDRANGE/HIGH-FREQUENCY
MODULE

TYPE 1
BASS MODULE

TYPE 1
BASS MODULE

MIDRANGE/HIGH-FREQUENCY
MODULE

TYPE 2
BASS MODULE

B&W
LOUDSPEAKERS

M A T R I X
800

DESIGN BACKGROUND

THE BASS UNIT

The low frequencies are handled by twin asymmetrical enclosures each containing a variation on the Matrix 801 bass driver with its own crossover network. In line with the other members of the 800 Series the low frequency cut-off follows a sixth-order Butterworth alignment.

The enclosures have only a small proportion of parallel faces, thus minimising standing wave problems. A Matrix divides the radiating surfaces into narrow strips, effectively pushing fundamental resonances outside the passband.

The bass modules are deliberately positioned high and low to attack the problem of uneven low frequency response due to room interactions. Each driver excites a different set of room modes to spread their effect.

THE MIDRANGE UNIT

The mid-frequency section utilises two Matrix 801 midrange drivers in a single Matrix enclosure. Vertical polar response irregularities have been avoided by tailoring the responses of the individual drivers so that only one driver is effective at the midrange/high-frequency crossover.

The size and baffle contours of the midrange enclosure/grille combination have received considerable attention to ensure a wide and even dispersion characteristic.

THE HIGH-FREQUENCY UNIT

Frequencies over 3kHz are reproduced by a new 32mm (1¼in) metal dome tweeter.

Originally developed for high-power/high-efficiency studio monitor use, its larger coil diameter and ferro-fluid cooling combine to enhance greatly the power handling. A sensitivity of more than 3dB above that required for the Matrix 800 effectively doubles its safe input capabilities.

THE CROSSOVER

The performance of excellent drive units must, by definition, be degraded to some extent by the introduction of components and wiring. The effects of speaker and interconnect cables are evidence of this. In the Matrix 800 crossover network, B&W, by careful acoustic design, have eliminated as many as possible of these elements.

Hard wiring, which ensures direct contact between component leads, is universally employed. Where connections have to be made, this is achieved by clamping together heavy duty gold-plated copper spade connectors. Each section has a completely separate crossover to virtually eliminate interactions. Polypropylene capacitors are used throughout.

ASSEMBLY

Identify bass modules types 1 and 2.
(Note that the two bass assemblies are mirror images of each other. Each complete speaker assembly includes one each of module types 1 and 2.) Attach one cast base plate to one type 1 module. The

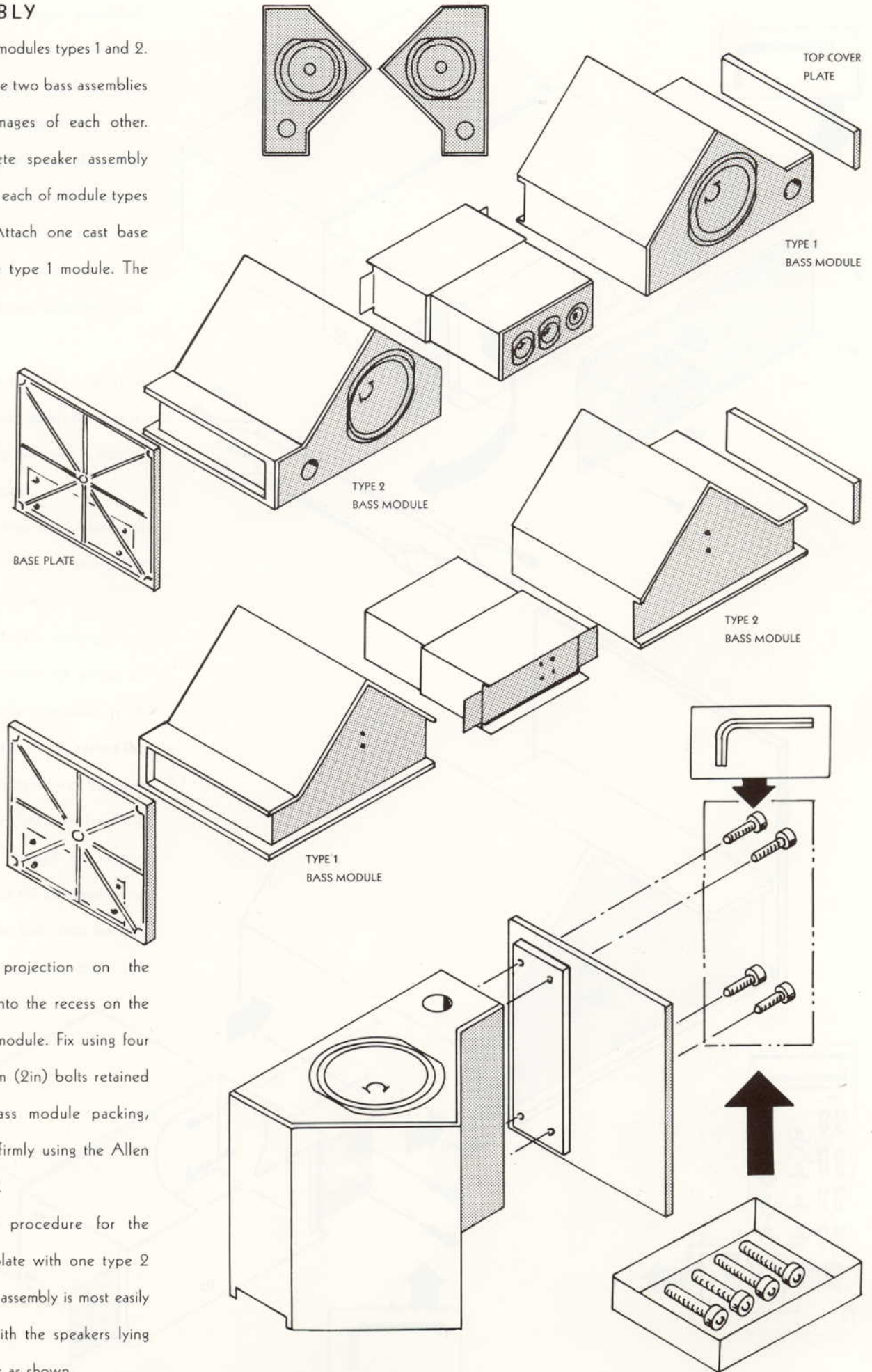

rectangular projection on the casting fits into the recess on the end of the module. Fix using four M8 x 50mm (2in) bolts retained from the bass module packing, and tighten firmly using the Allen key supplied.

Repeat this procedure for the other base plate with one type 2 module. The assembly is most easily continued with the speakers lying on their sides as shown.

Using the Allen key provided, remove the six M5 × 10mm (3/8in) bolts which secure the back plate to the steel bridge section, and remove the plate complete with the midrange and high-frequency crossover networks. If necessary, slacken the five gold screws to release the harness from the crossover boards.

In each bridge section you will also find a two-part external harness. Remove this for later use in installation of the system.

Remove the two large blocks of acoustic absorbent, to access the inner fixing positions.

Offer up one of the midrange/high frequency modules to either of the bass module assemblies, with the steel tongue resting against the back of the enclosure. Fit two M8 × 25mm (1in) bolts from the accessory kit through the tongue into the rear of the bass enclosure and two similar bolts into the top of the enclosure from inside the bridge.

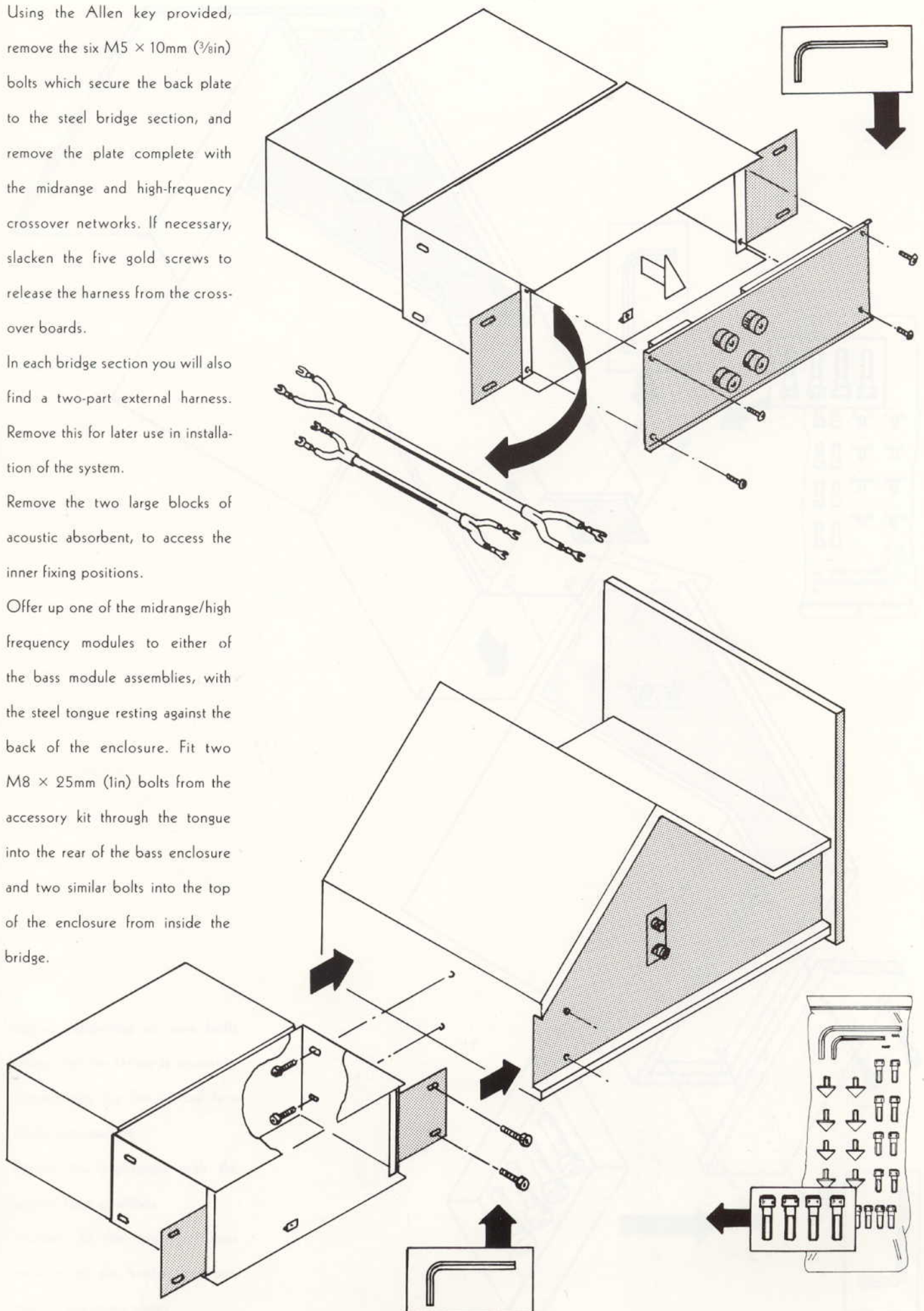

AMPLIFIER, CONTROL UNIT, SOURCE EQUIPMENT AND CABLES

The recommended limits of RMS power output for the driving amplifier are 150W min. 800W max. (into 8Ω). It should be stated that it is impossible to quote amplifier power output precisely, as it depends to some extent on the type of music being reproduced. Similarly, the required amplifier power will depend on room volume and the sound level required by the listener.

It is generally true to say that too high a power output is better than too low, because it allows more head-room for transients and reduces the risk of clipping, with its attendant sharp rise in distortion.

THE CONTROL UNIT

The control unit – although it deals with small voltages rather than large currents as in the case of the power amplifier – is an equally critical part of your listening chain. Choose with care, in the knowledge that the ultimate test for audio components is critical listening. At B&W's research department there are many different combinations of control units, amplifiers and source components such as analogue/CD players, tuners, etc. It is our experience that each unit (to say

nothing of the interconnecting cable) is a variable, and the final listening chain is a combination of variables which should be carefully listened to before making a final choice.

CD PLAYER, ANALOGUE TURNTABLE AND TUNER

The comments in the previous paragraph apply equally to these items of equipment. CD players have now been available for some years and considerable advances have been made. In its present state of development the CD player, when coupled with the best recordings made on this medium, can provide the most exceptional source material, totally worthy of the finest equipment with which it is associated.

CABLES

The subject of electrical connection and the loudspeakers is dealt with under 'Installation'.

There remains the question of interconnecting cables between the various pieces of equipment and the power amplifier. A number of excellent cables are available on the market and audible differences certainly exist between them. We suggest, therefore, that you choose one of the better cables for this purpose, after consideration of the published reports.

B & W PRESENT – LISTENING SUGGESTIONS

Your Matrix 800 system will take you a giant step nearer to listening to the music rather than to the loudspeakers. You will hear much more of the desirable ambience and detail in good recordings; unfortunately, the faults in poor recordings will also be revealed.

B&W have produced three special compact disc recordings that will enable you to enjoy a full appreciation of your new system. They are available from your dealer:

BW001 The Academy of Ancient Music: Christopher Hogwood.

BW002 Live at the Montreux Jazz Festival.

BW003 The EMI Abbey Road Classical Collection.



HIGH-PASS ALIGNMENT FILTER

The external filter supplied is an integral part of the low frequency acoustic alignment. With it the response extends to 19Hz (-6dB), and sub-sonic frequencies, which can cause excessive cone excursion and inter-modulation distortion, are filtered out.

The unit can be connected permanently between the control amplifier and power amplifier, or within a tape monitor loop if it is wished to switch it out at any time. The loudspeakers may be used perfectly satisfactorily without the filter, at which time the system response approximates to a fourth-order Bessel alignment (-6dB at 32Hz).

Indeed, with many recordings having little information below 40Hz, the effect of the filter can be quite subtle.

PERMANENT CONNECTION

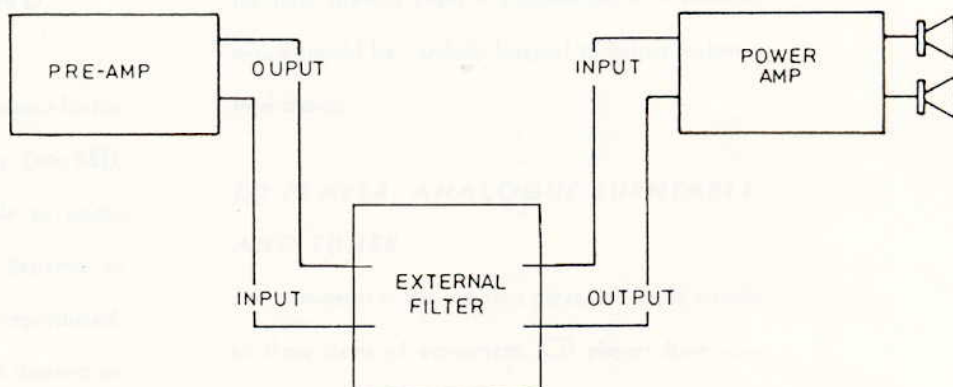

SWITCHED CONNECTION

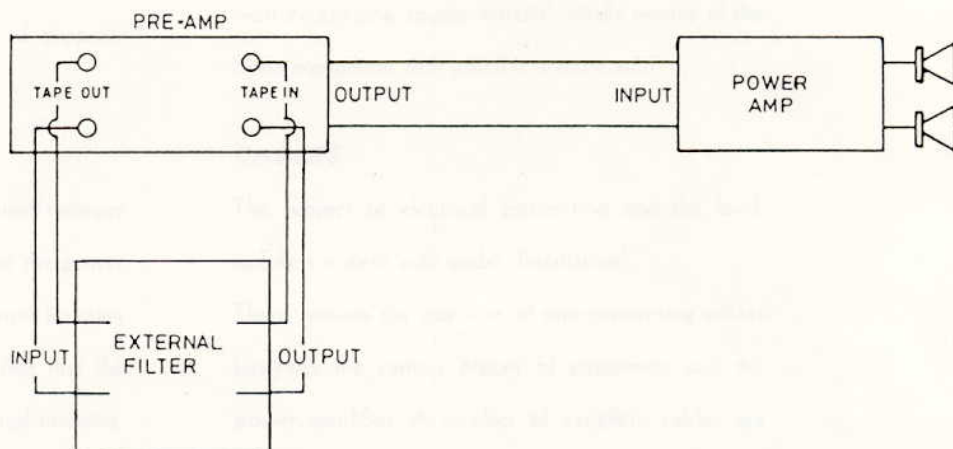

THE LISTENING ROOM AND POSITIONING YOUR LOUDSPEAKERS

It has been recognised for some time that the shape and dimensions of a room can have a major impact on the perceived extension and linearity of loudspeakers in the low frequency region.

The reflection of sound from room walls sets up resonant modes, the frequencies of which depend on the distances involved. The effects are more pronounced at low frequencies because the spacing between the modes is greater.

By placing the bass drivers in the Matrix 800 at different heights, so that each excites a different set of modes, B&W have effectively

reduced the problems of room interaction. The result? A more evenly perceived bass response.

The Matrix 800 is likely to appeal to people who need higher levels than the Matrix 801 can comfortably provide. Rest assured that the high efficiency has not detracted from the proven virtues of neutrality and low coloration of Matrix 801.

PLACEMENT OF LOUDSPEAKERS

A great deal of effort has been spent in the evaluation of the Matrix 800 in as many different environments as possible. Whilst the advantage of spaced bass drivers is both audible and measurable, the Matrix 800 nevertheless benefits from experimentation in

positioning.

The 800's sheer size can result in modification of the room acoustics by the speakers themselves. The normally accepted rules such as avoidance of corners and close proximity to walls still apply.

The superb resolution provided by the Matrix 800 system does mean, however, that time spent in fine adjustment of the speakers in relation to their environment can be enormously beneficial to the imaging and overall balance. Good results have been obtained under conditions varying from widely spaced and angled-in speakers, to narrow-room situations where the speakers were no more than 1.5m (60in) apart and facing straight down the room.

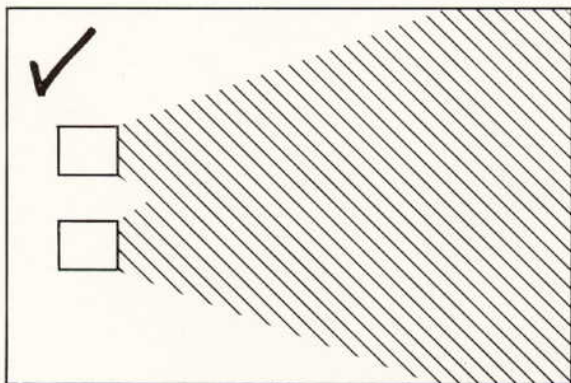
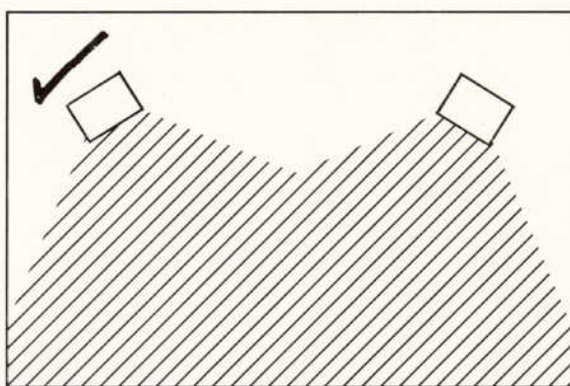
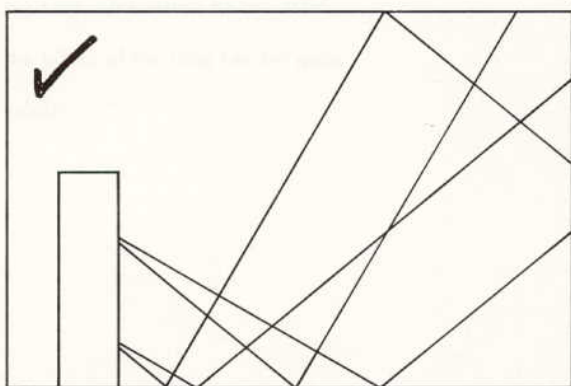

ALTERNATIVE WIRING OPTIONS

Bi-/tri-wiring. Worthwhile improvements may be obtained by the progressive replacement of links by multiple loudspeaker leads, which helps to minimise cable-borne interactions between crossovers.

Bi-wiring is strongly recommended as a minimum requirement.

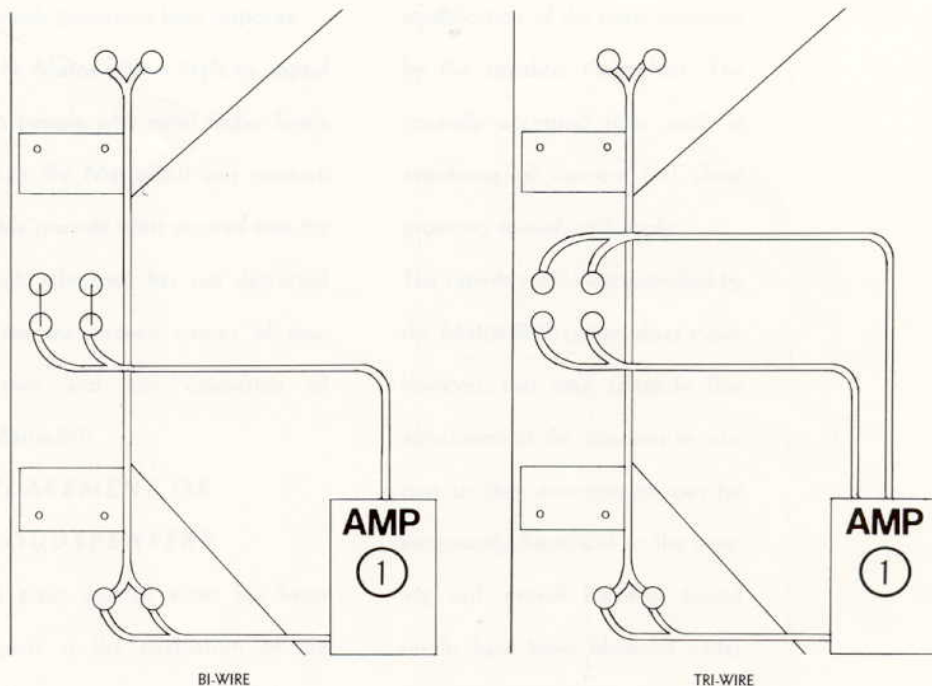

Bi-/tri-amping. Ultimately, the use of two or more amplifiers can give further sonic improvements. It is essential, however, that the amplifier gains on each system are very closely matched, in order to maintain the correct system balance.

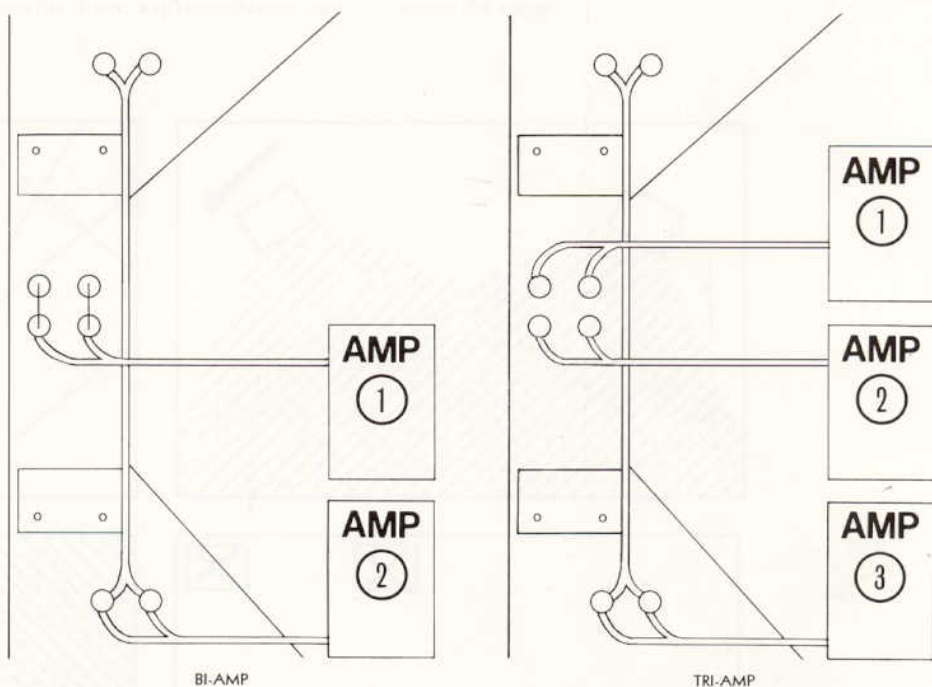

INSTALLATION

Electrical connection of the loudspeakers requires that each of the four red terminals is connected to the positive (+) terminal of your amplifier and likewise the white terminals to the negative (-) amplifier terminal. The external harness supplied with your speakers enables the simplest connection to be made utilising one amplifier and one speaker lead.

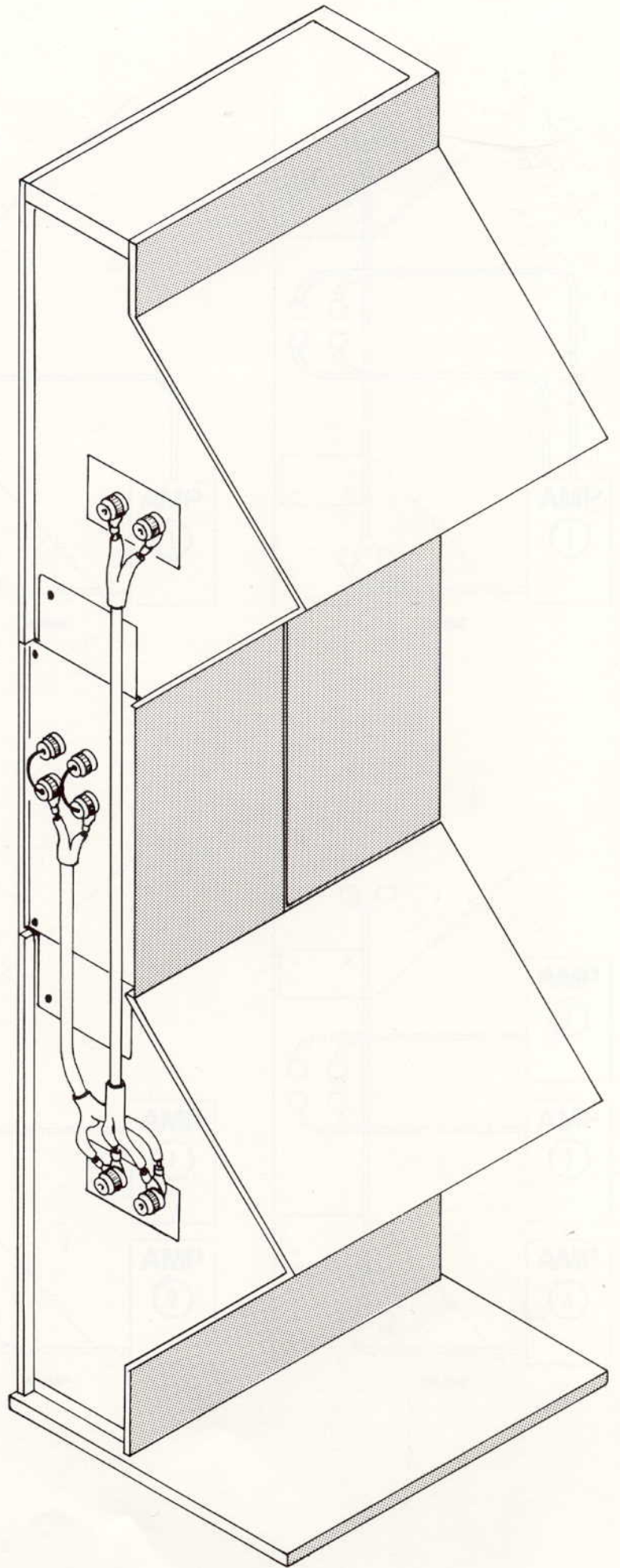
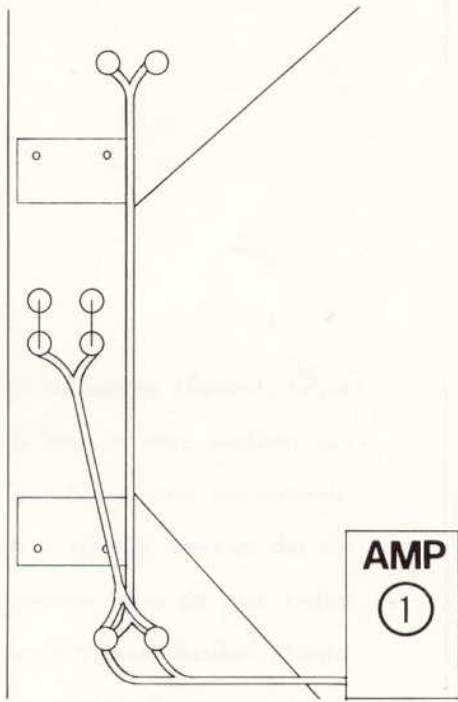

If the systems are to be used on soft flooring, the stabilising cones, supplied in the accessory pack, should be fitted when the best room position has been determined, as described in a later section – 'Listening Room and Positioning Your Loudspeakers'. If located on a hard floor the base has rubber feet fitted, and the use of the cones is left to your discretion.

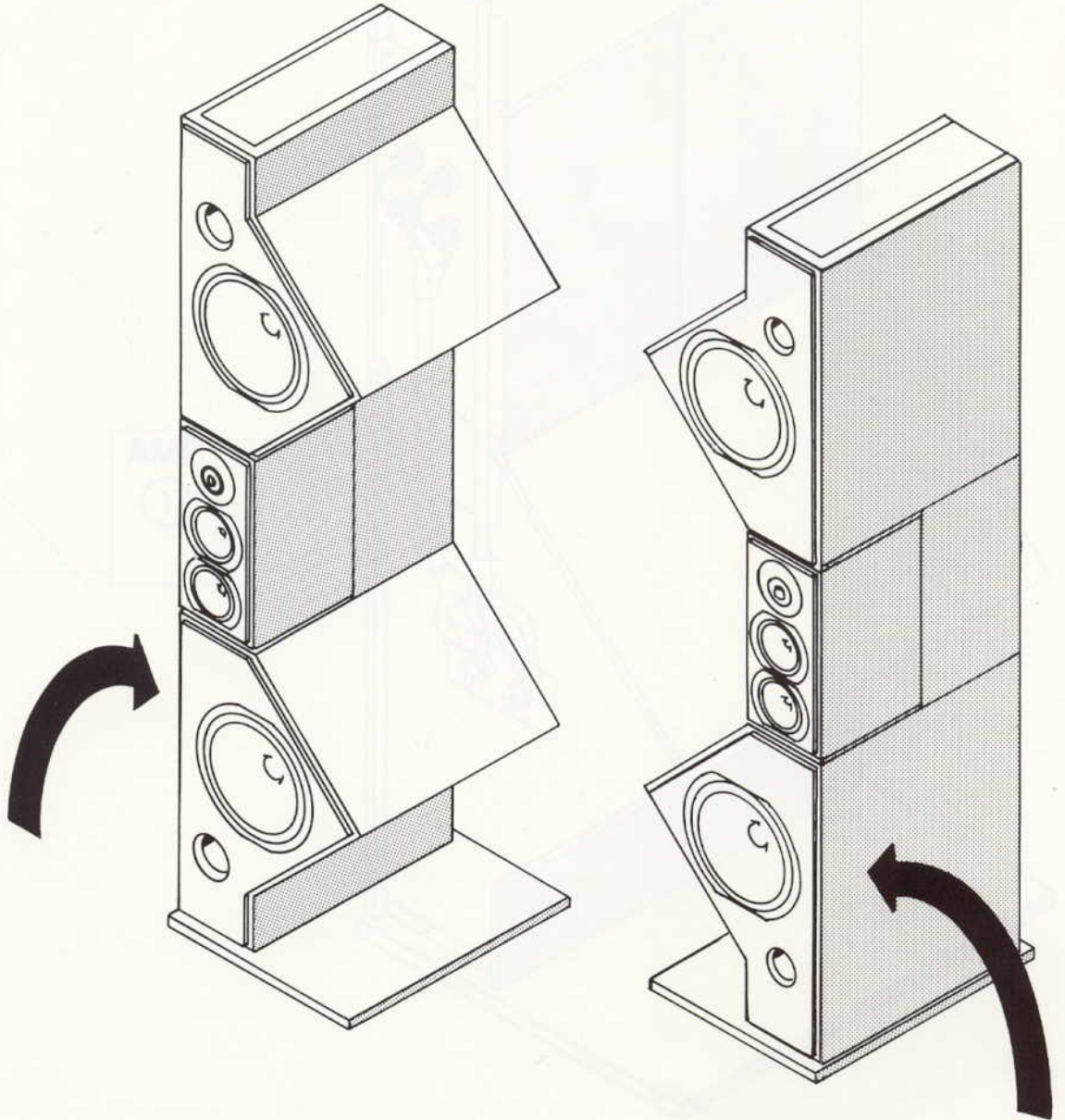
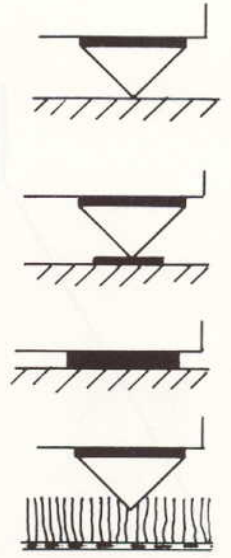
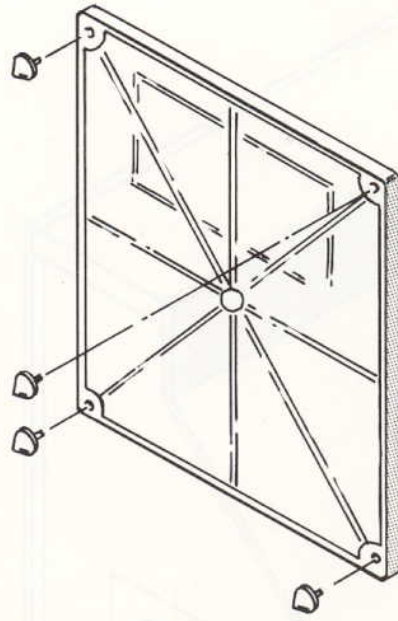

INTERNAL ELECTRICAL CONNECTION

Connect the six numbered wires from the rear of the midrange/high-frequency enclosures to their relevant terminals on the crossover boards and tighten down firmly. Note that two wires run to terminal 4.

Replace the blocks of acoustic absorbent and the rear panels, using the M5 × 10mm (3/8in) bolts, which were removed earlier.

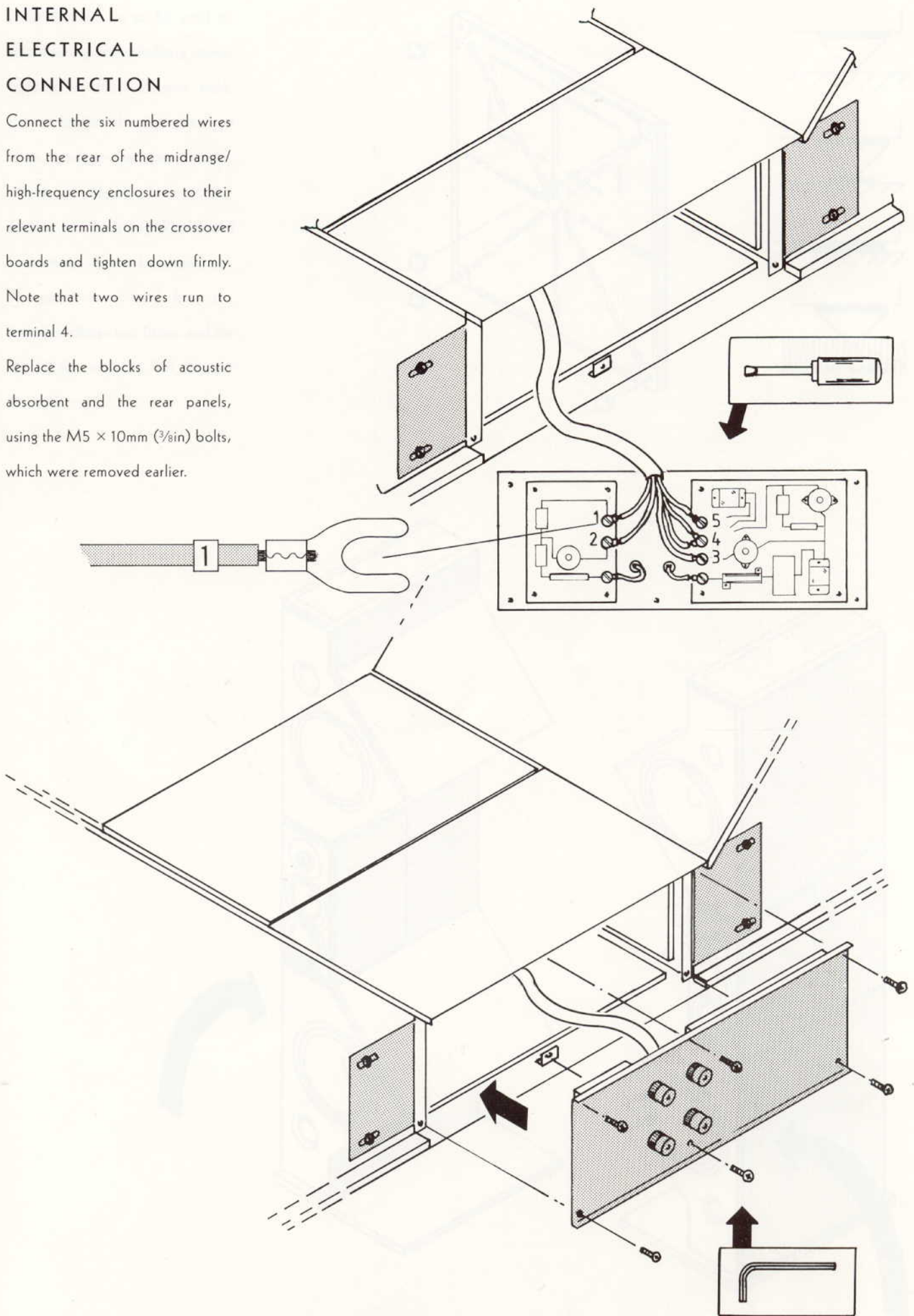

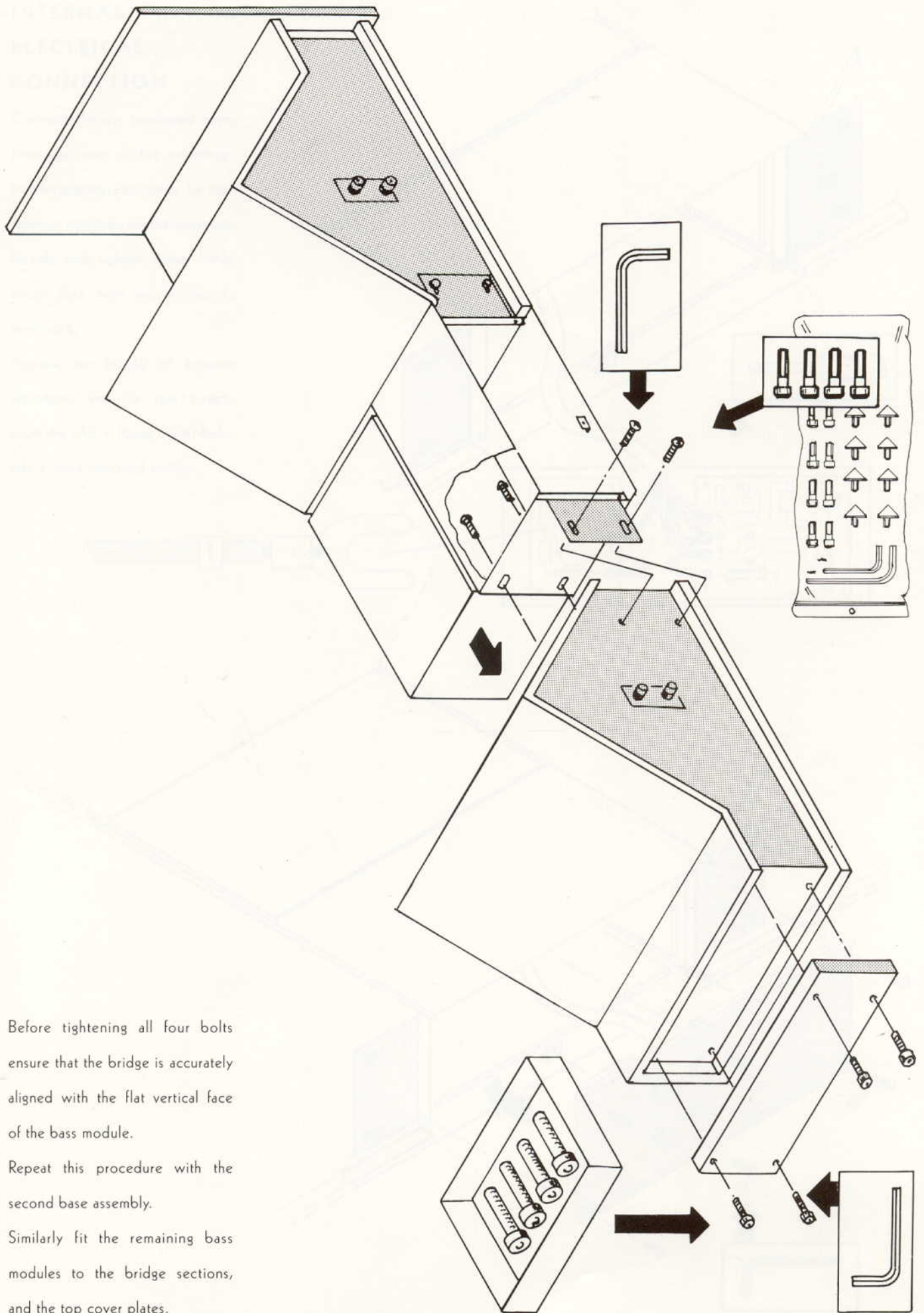

Before tightening all four bolts ensure that the bridge is accurately aligned with the flat vertical face of the bass module.

Repeat this procedure with the second base assembly.

Similarly fit the remaining bass modules to the bridge sections, and the top cover plates.

AFTERCARE

The Matrix 800 may be finished in wood veneer or paint. The greatest care should be exercised when cleaning the enclosures. Under no circumstances should abrasive cleaners be used. A soft, damp cloth is all that is necessary to clean paintwork.

Wood veneer should be treated in the same way that you would treat any fine piece of furniture. Aerosols should be first sprayed onto a piece of cloth to avoid overspray onto the grille or drivers.

The grilles may be cleaned using the brush provided, after first removing them.

Avoid touching the units, especially the metal dome tweeter, as irreversible damage could result.

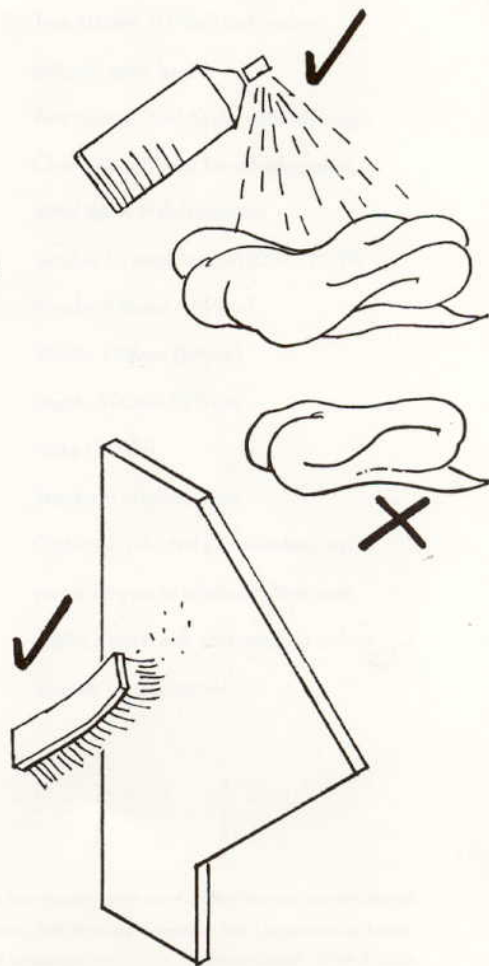
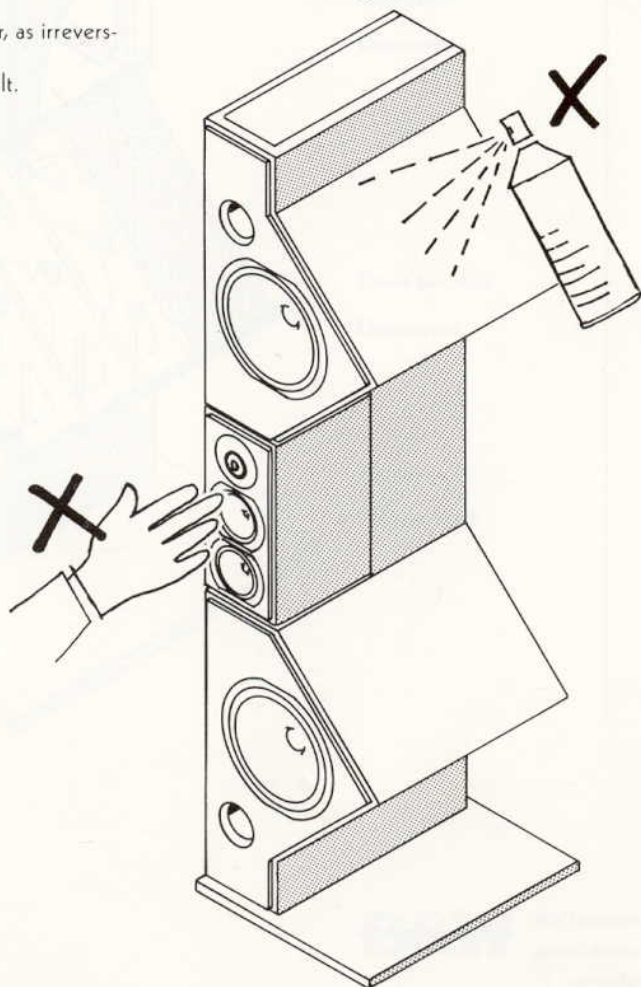
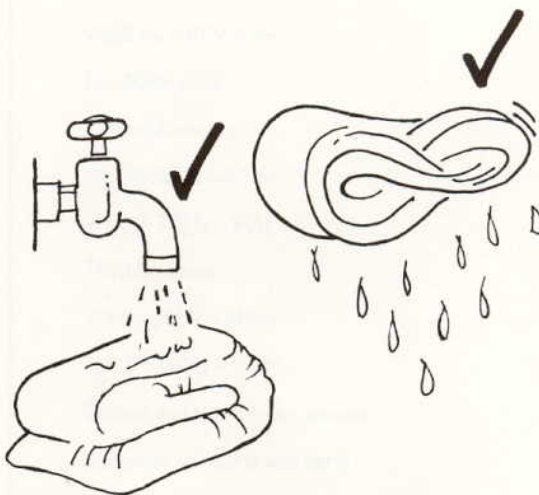
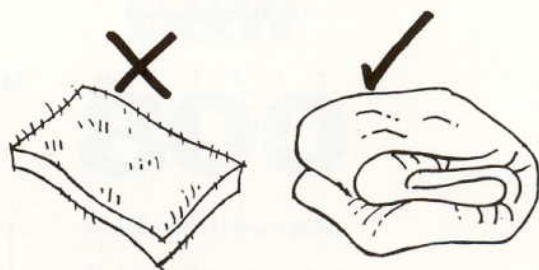
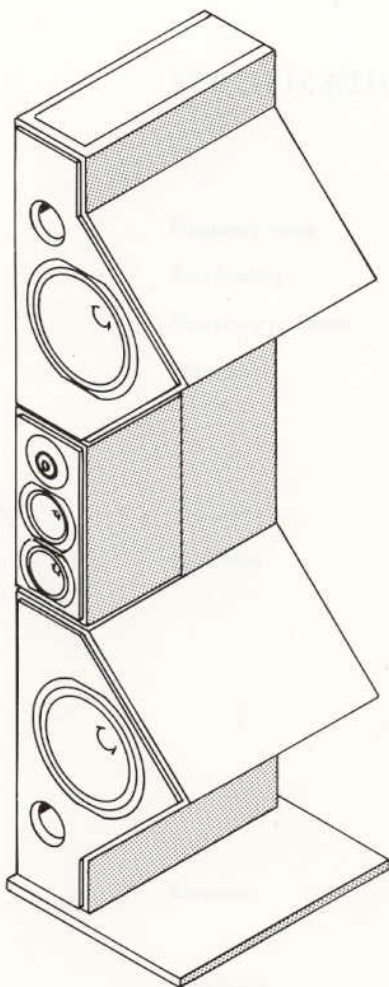

B&W
LOUDSPEAKERS

SPECIFICATION

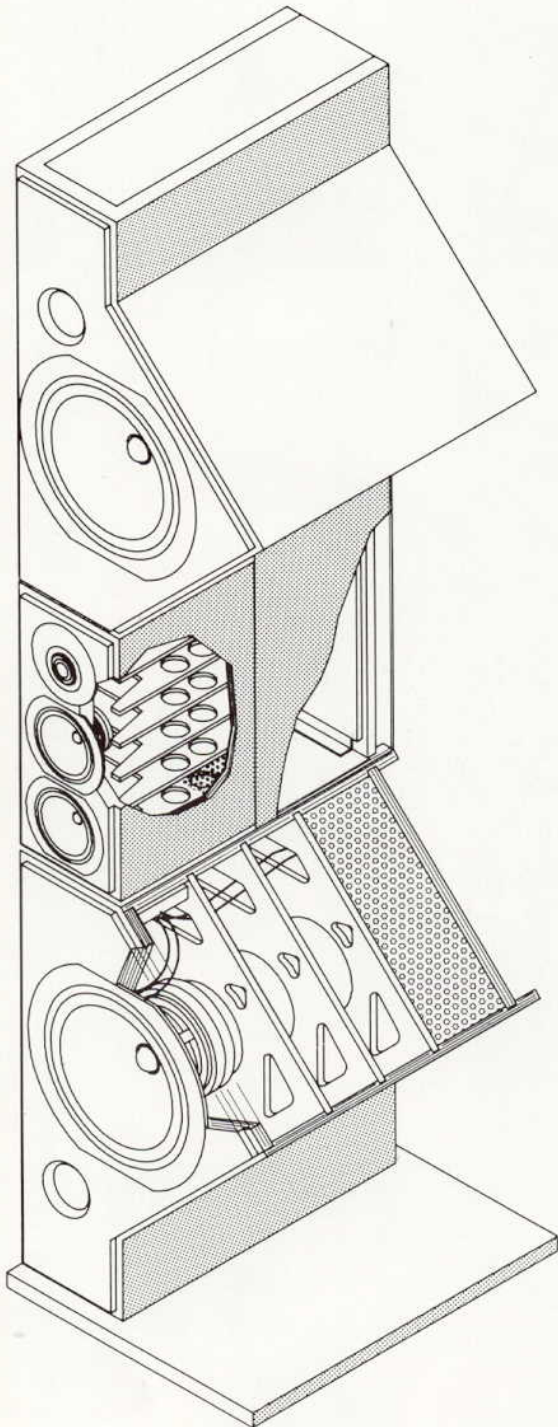
M A T R I X
800

Frequency range	(-6dB points) 19Hz - 21kHz
Bass loading	Sixth-order Butterworth alignment
Frequency response	23Hz - 20kHz \pm 2dB free-field
Dispersion	20Hz - 20kHz Horizontal: +0 - 3dB over 60° arc Vertical: +0 - 3dB over 10° arc
Sensitivity	93dB for 2.83V at 1m
Distortion	For 100dB at 1m Second harmonic: <1.0% 20Hz - 70Hz <0.5% 70Hz - 20kHz Third harmonic: <1.0% 20Hz - 50Hz <0.5% 50Hz - 20kHz
Crossover	Second and fourth-order acoustic responses at 380Hz and 3kHz
Impedance	4 Ω (minimum 3 Ω)
Drive units	Two 300mm (11 $\frac{3}{4}$ in) high-power polymer cone bass Two 126mm (5in) Kevlar cone midrange One 32mm (1 $\frac{1}{4}$ in) ferrofluid-cooled, metal dome high-frequency
Power handling	Suitable for amplifiers of 150W - 800W
Dimensions	Height: 1915mm (75 $\frac{3}{8}$ in) Width: 488mm (19 $\frac{1}{2}$ in) Depth: 590mm (23 $\frac{3}{4}$ in)
Weight	110kg (240lb)
Cabinet finish	Standard: black or white Optional: selected pair-matched real wood veneers of black ash, birds-eye maple, natural oak, rosewood or walnut Special: on application

B&W
LOUDSPEAKERS

B&W Loudspeakers Ltd reserve the right to amend details of their specifications in line with technical developments. B&W Matrix are trademarks of B&W Loudspeakers Ltd, England.

© Copyright B&W Loudspeakers Ltd.

Printed in England GSB A 0573/90